

# MotorGuide® REPAIR PARTS

Model:

# 675

## BEAST 675

### SPECIFICATIONS:

Year of Intro	1993
Thrust	65LBS
Volts	24/36VDC
Amp Draw	0 to 30 amps
Mount	20 Bow
Speeds	Variable

### PARTS ORDERING & TECH ASSISTANCE

MotorGuide Consumer Relations  
 Phone 918-831-6989  
 Fax 800-982-8093

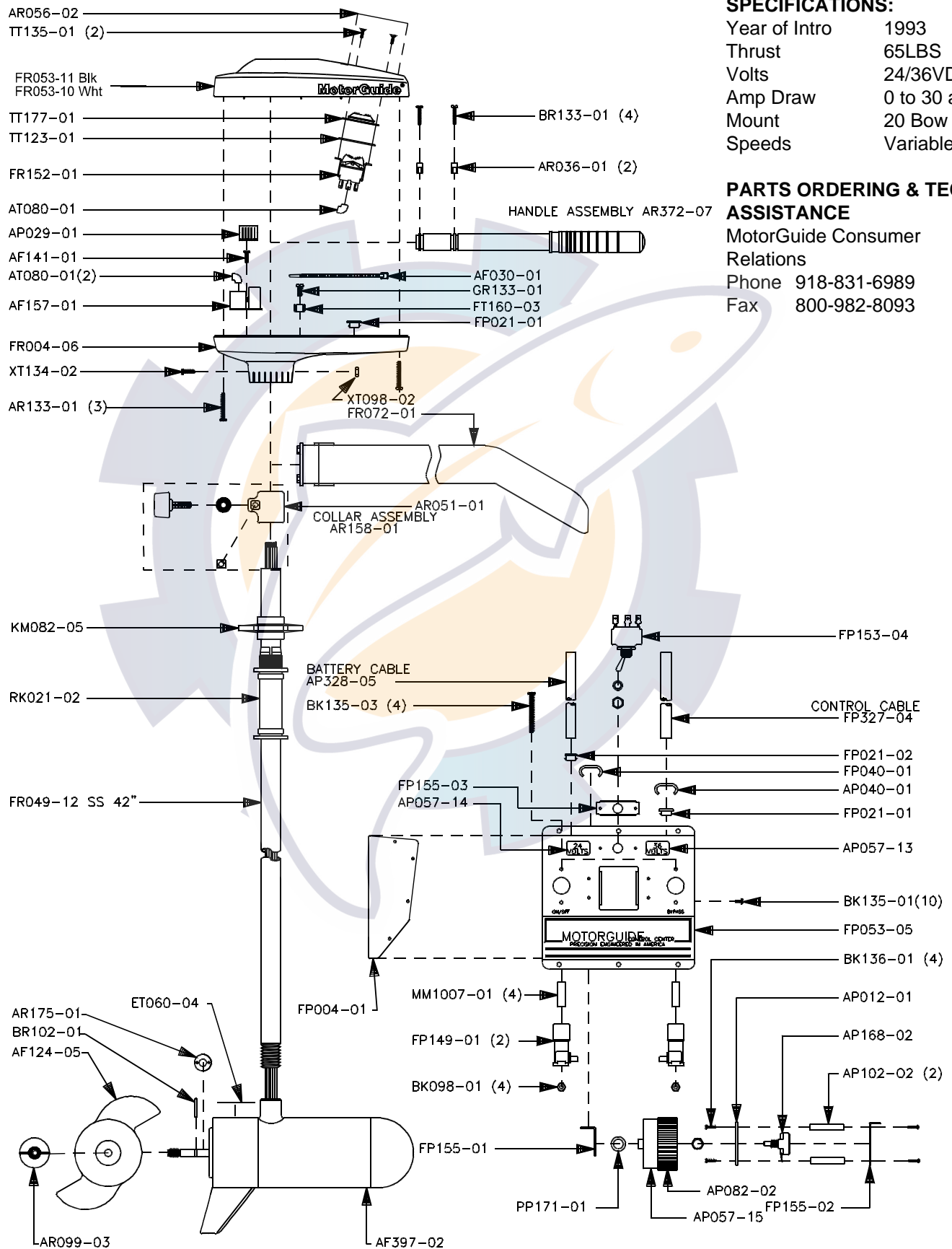

LOWER UNIT BREAKDOWN

Model:  
**675**

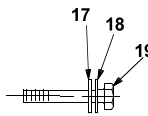
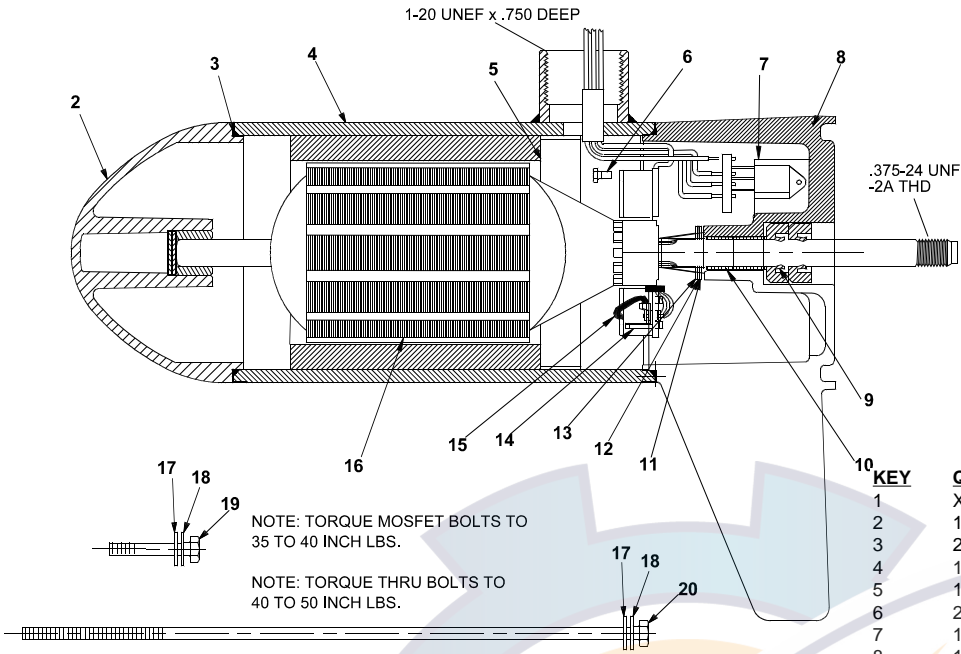

NOTE: TORQUE MOSFET BOLTS TO 35 TO 40 INCH LBS.

NOTE: TORQUE THRU BOLTS TO 40 TO 50 INCH LBS.

DIRECTION OF ROTATION IS COUNTER CLOCKWISE WHEN VIEWED FROM PROPELLER END WITH RED POSITIVE & BLACK NEGATIVE.

KEY	QTY	DESCRIPTION	PART NO.
1	X	MOTOR	AF397-02
2	1	NOSE CAP	JF3212-01
3	2	O RING SEAL	MR217-01
4	1	HOUSING ASY	AF3210-01
5	1	RETAINER	JF233-01
6	2	BRUSH CARD SCREW	MR228-01
7	1	DURA AMP MODULE	JF096-07
8	1	COMM CAP	JF3205-04
9	2	SHAFT SEAL	MR223-01
10	1	BEARING	MR206-01
11	1	NYLATRON WASHER	MR226-01
12	1	WASHER	MR227-01
13	1	E RING	MR219-02
14	2	BRUSH SPRINGS	MR214-02
15	1	BRUSH ASY LESS SPRING	AF3201-04
16	1	ARMATURE 3.5"	AF3207-01
17	4	STATIC SEAL	MR222-01
18	4	THRU BOLT WASHER	MR216-01
19	2	DURA AMP SCREW	MR229-04
20	2	THRU BOLT	MR218-11

WIRING

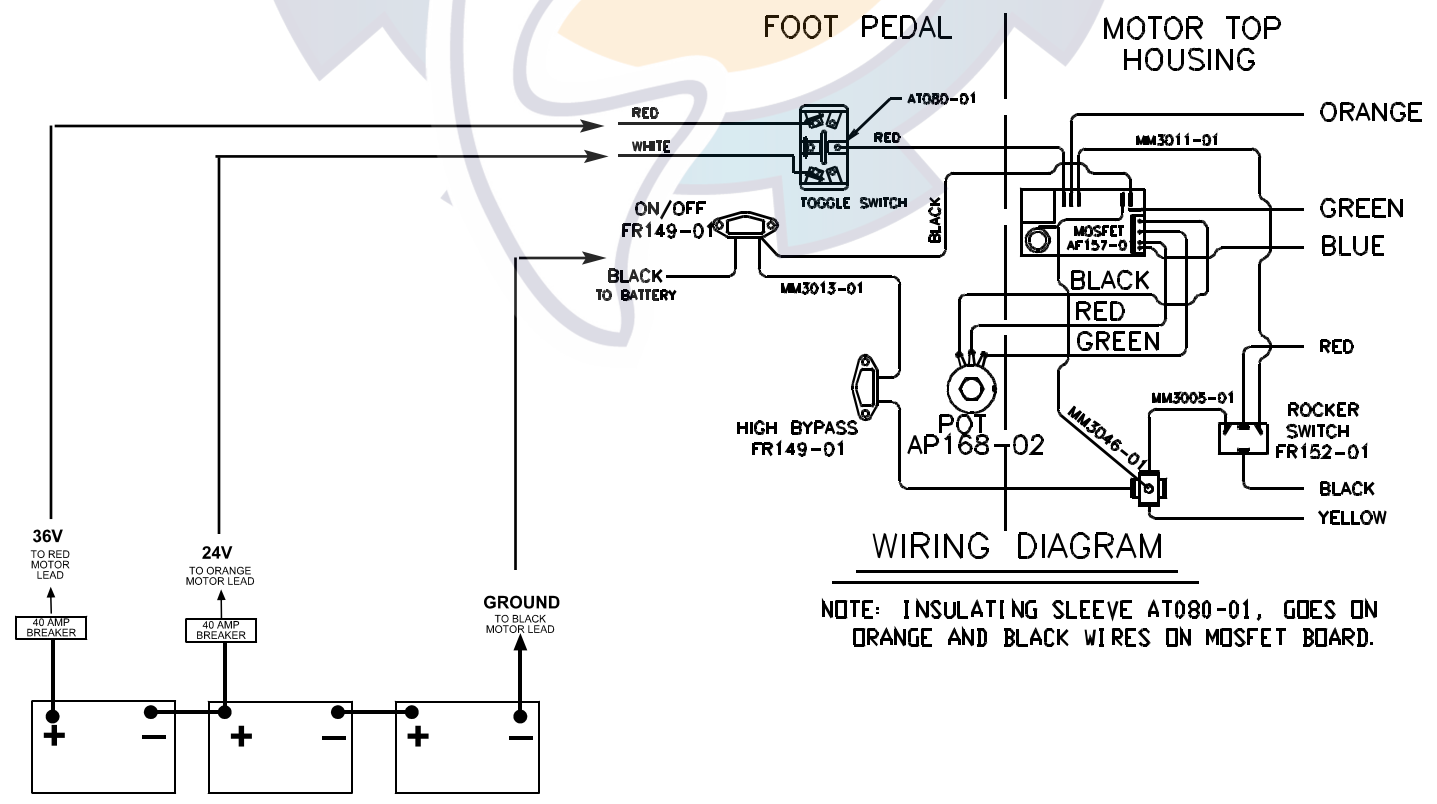

NOTE: INSULATING SLEEVE AT080-01, GOES ON ORANGE AND BLACK WIRES ON MOSFET BOARD.